

ROBOTIC PAINT GROUP LTD

MASK PRODUCTION MACHINE

SPECIFICATIONS

Voltage	220V/380V 50-60Hz
Input power	3-10KW
Output Frequency	20KHz
Productivity	80-110 pcs/min
Mask size	175X (80-100) MM
Nonwoven Layers	1-4 Layers
Nonwoven Material	10-20 GSM
Dimension	(3000-6000) X3000X1800MM
Weight	1000-3000KG

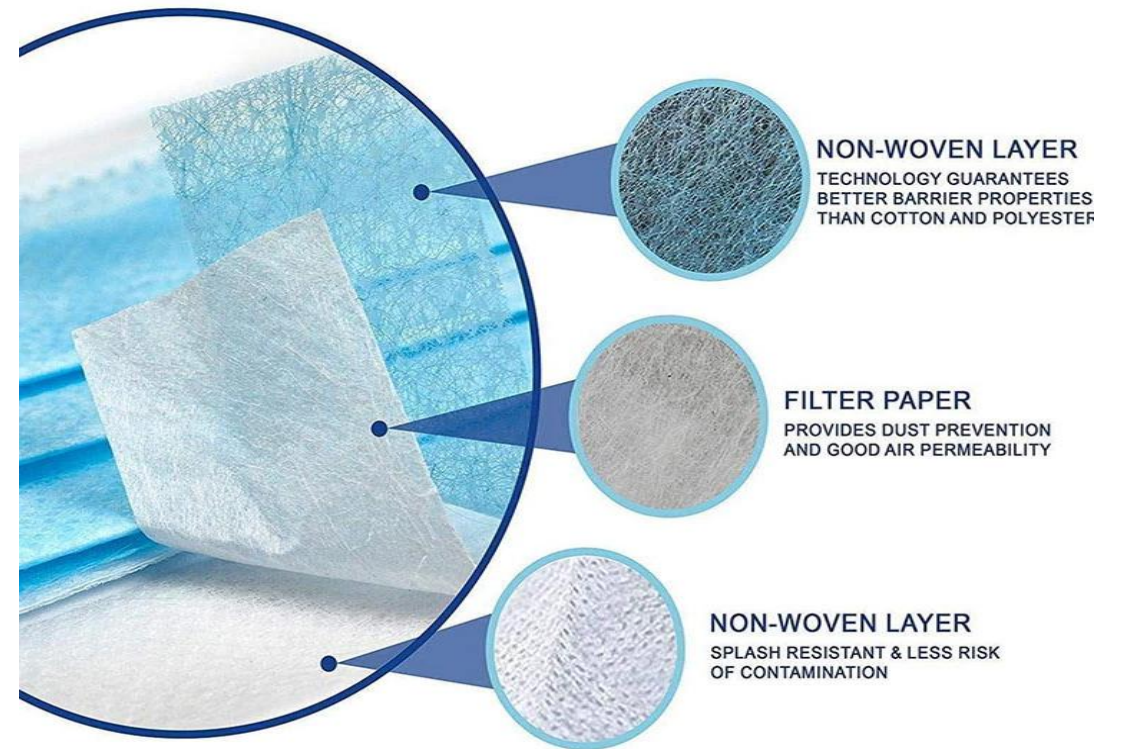

PROCESS FLOW

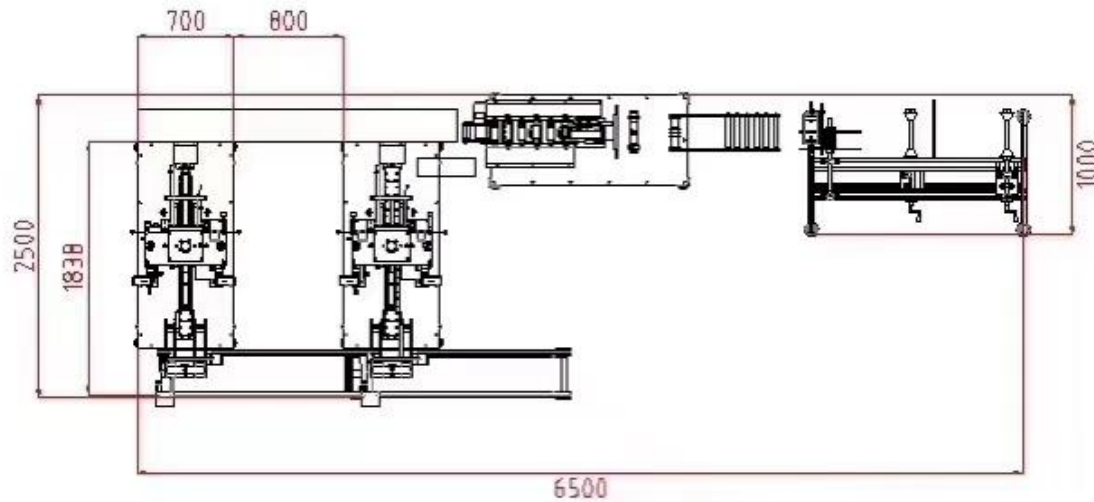
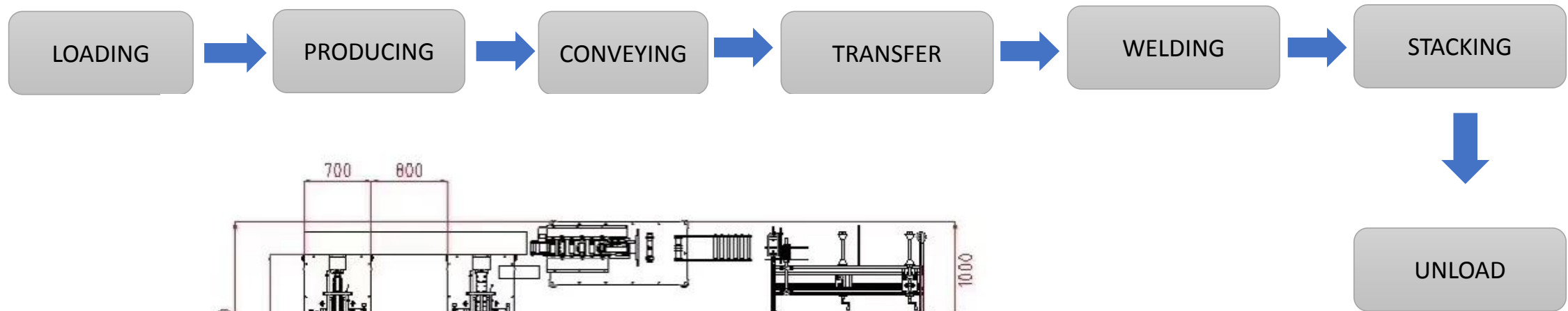

LAYOUTS

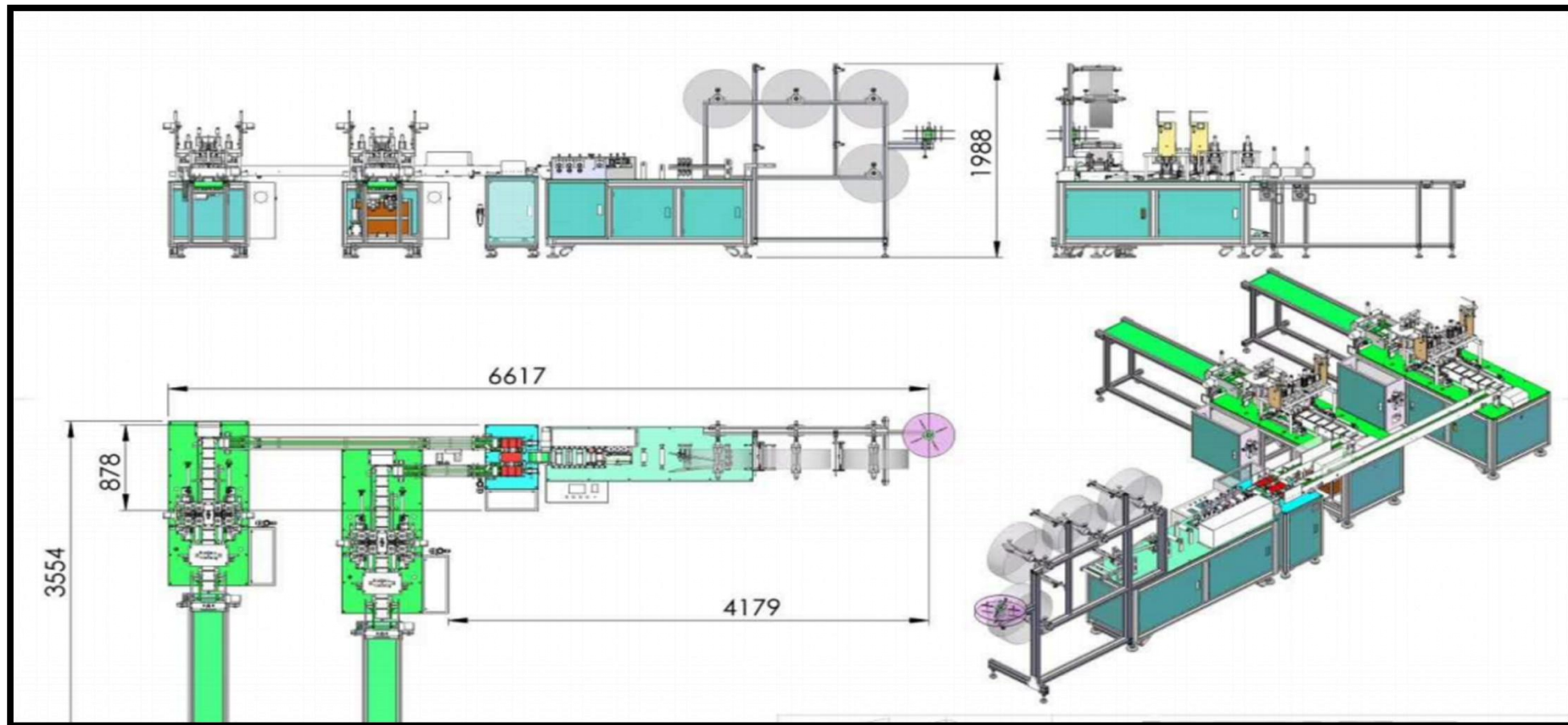

STRUCTURE

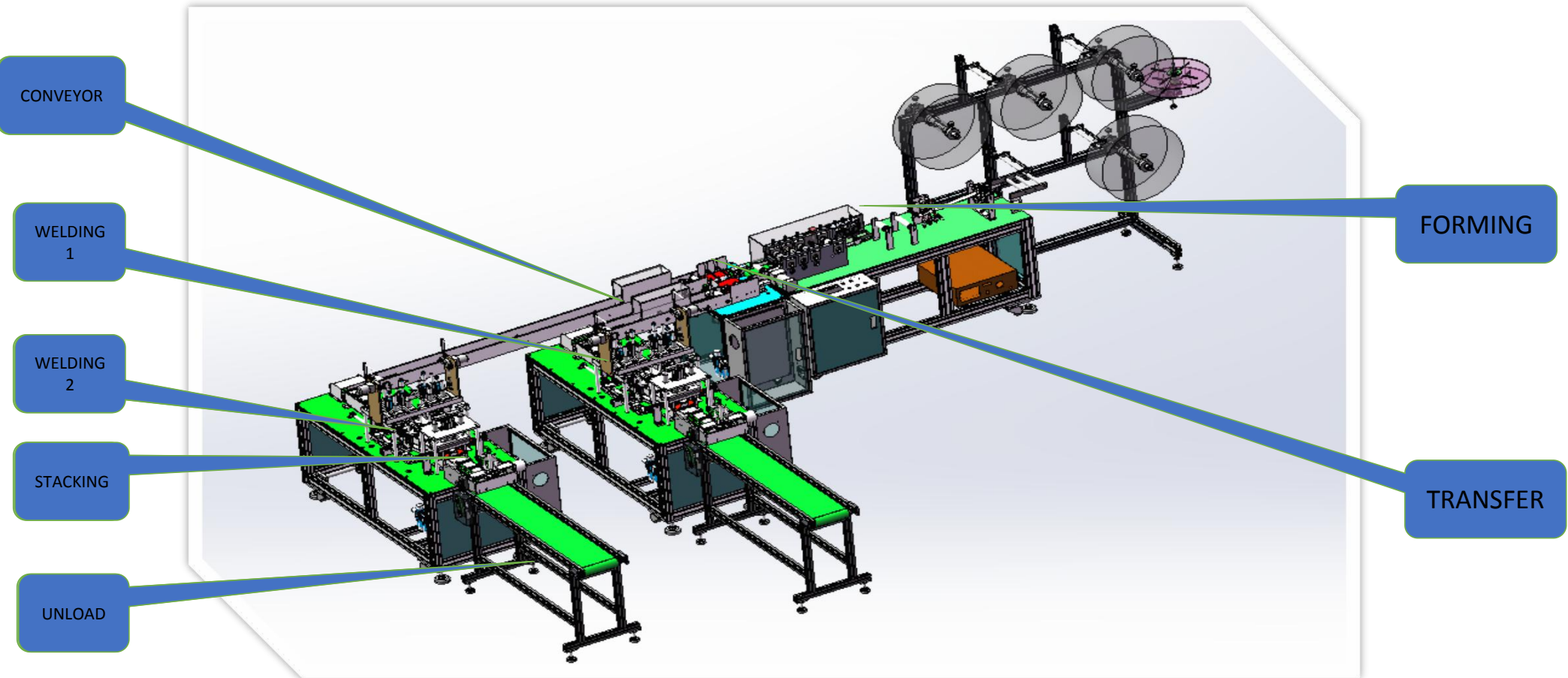

FORMING STRUCTURE

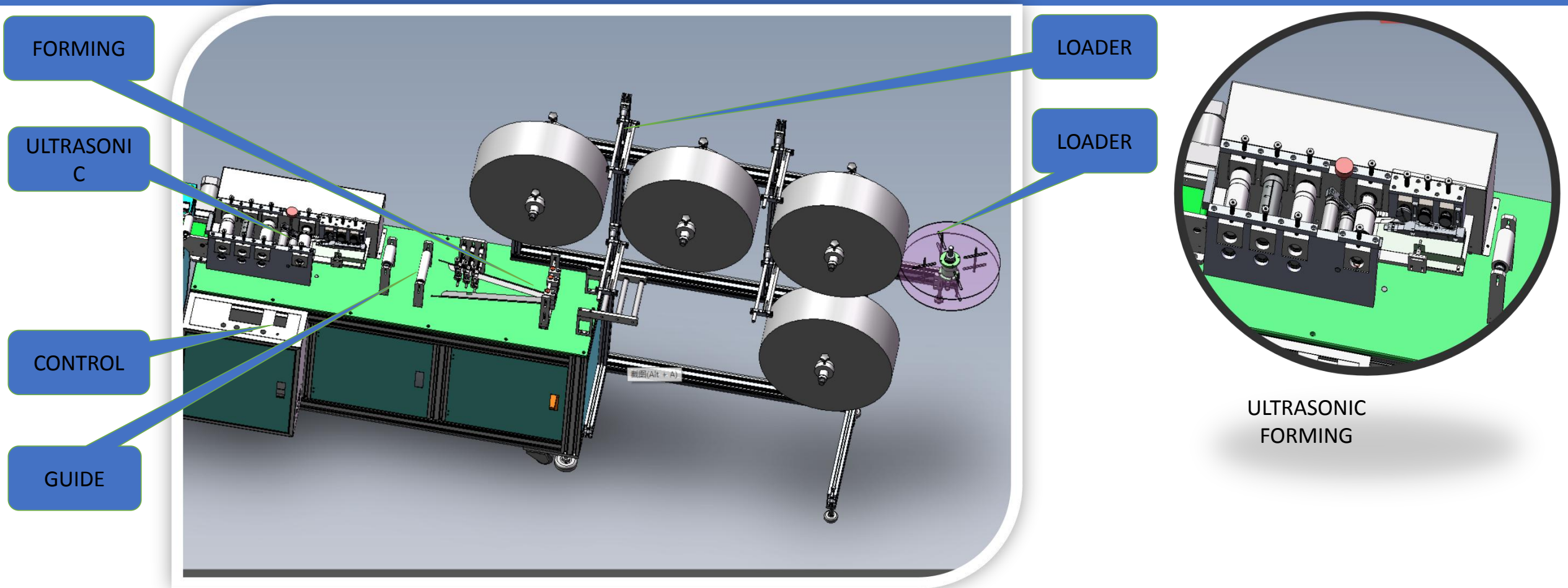

TRANSFER SYSTEM

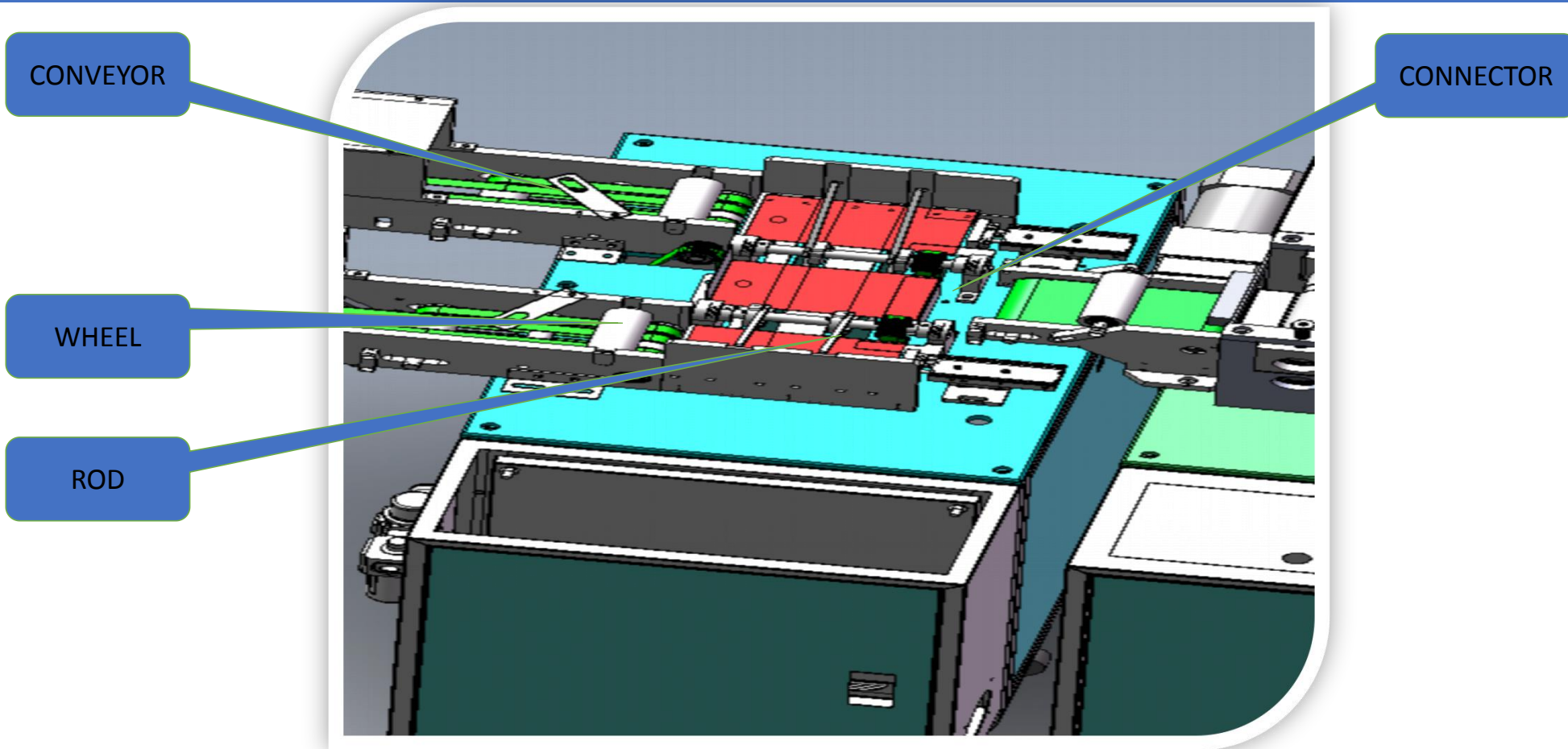

CONVEYOR SYSTEM

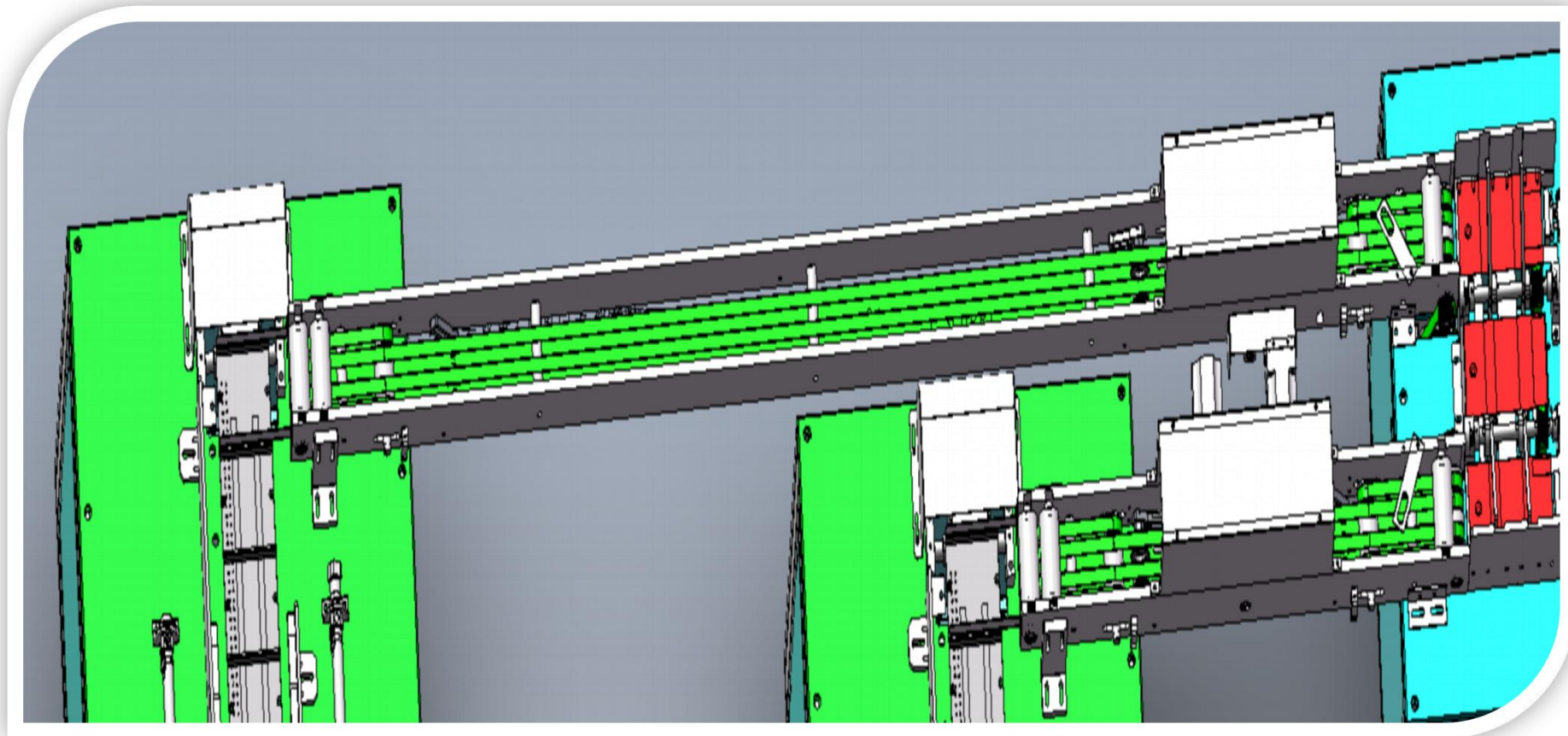

EAR LOOP WELDING SYSTEM

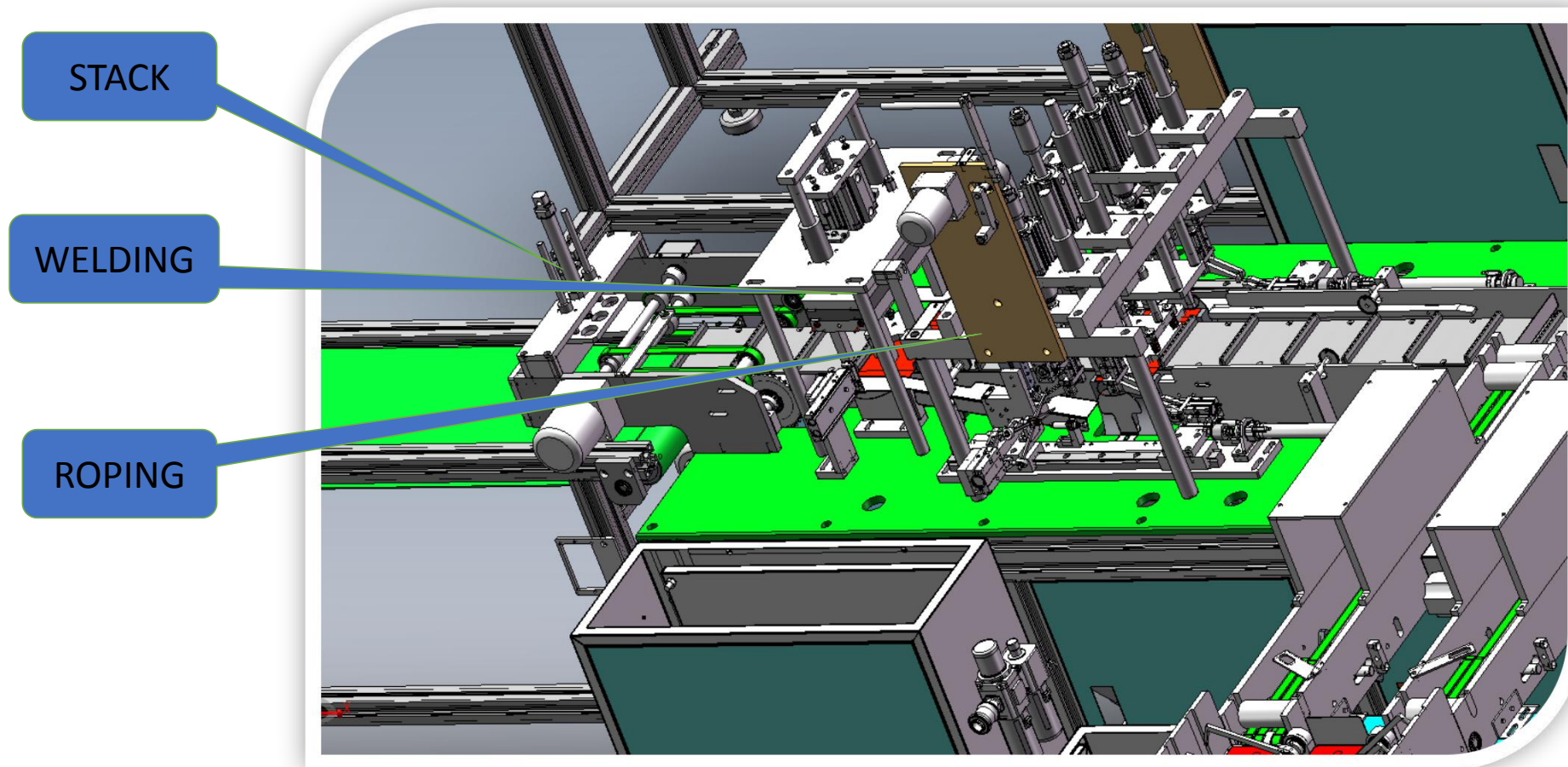

WELDING SYSTEM 2

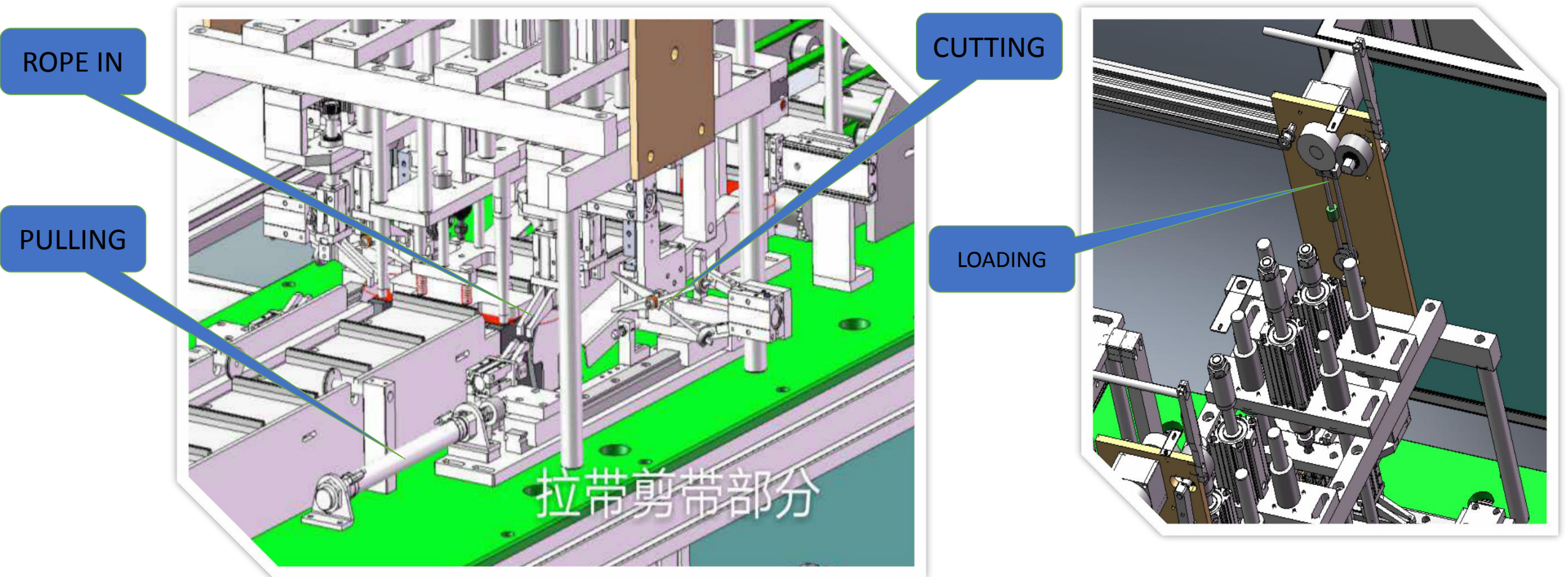

WELDING SYSTEM 3

WELDING

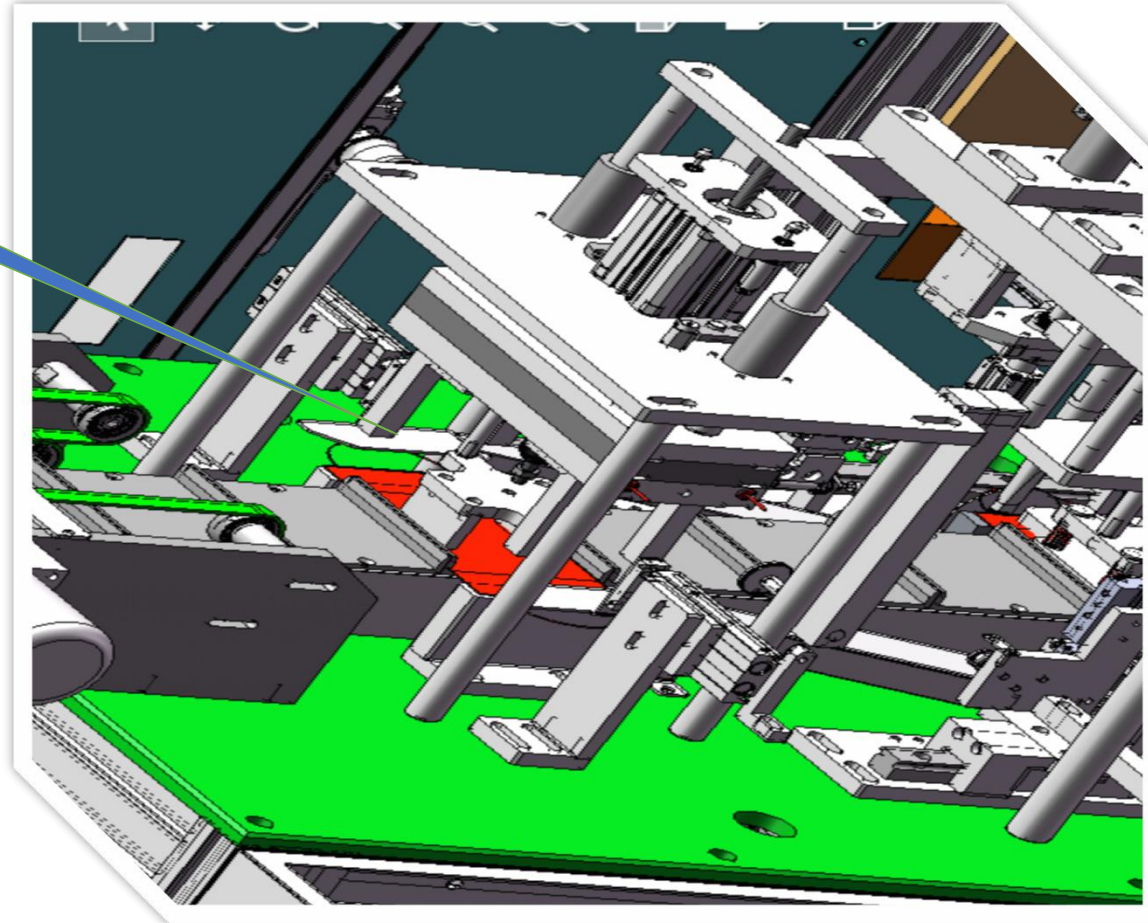

STACKING SYSTEM

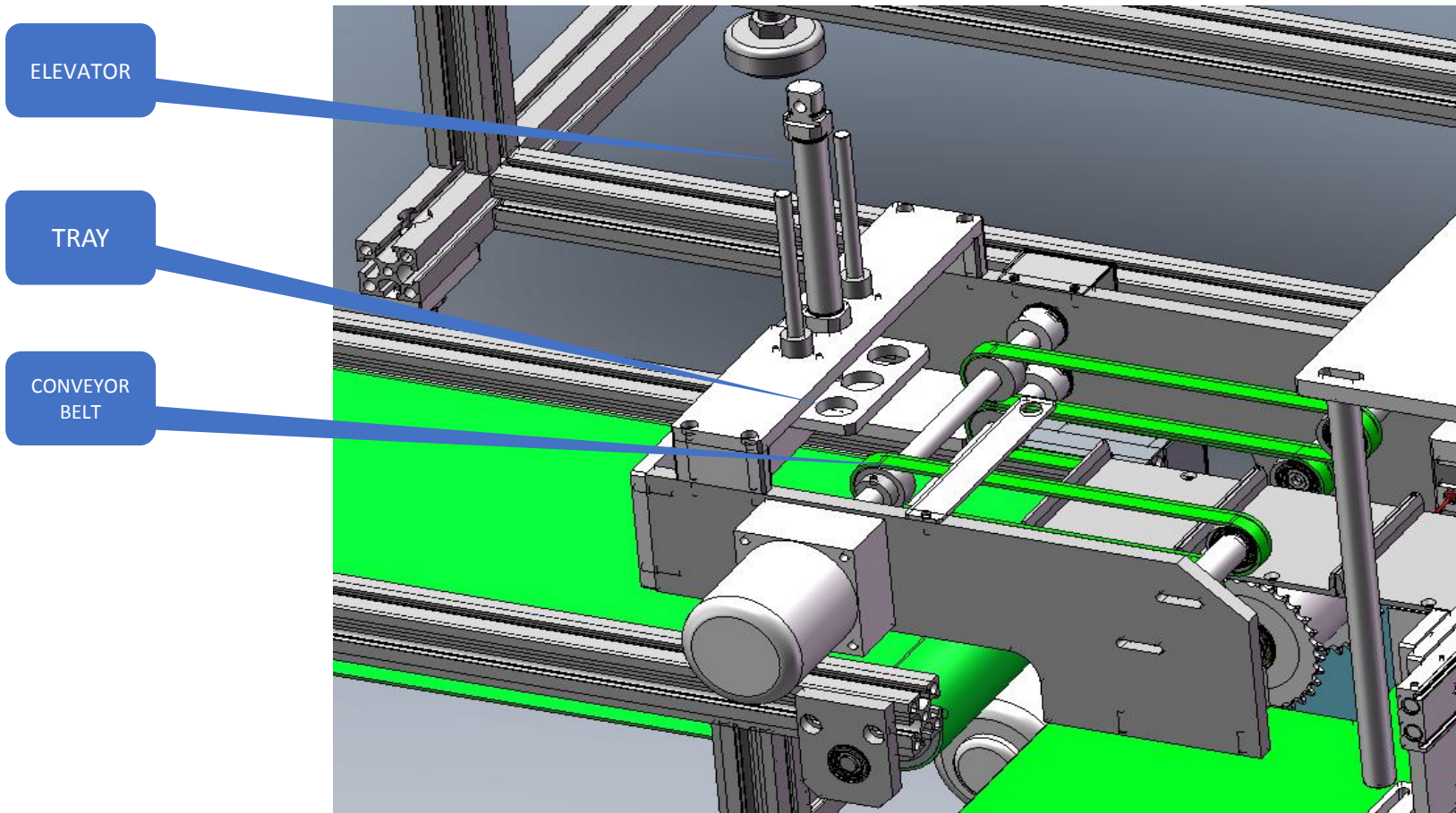

1-70PCS ONE STACK

UNLOADER

CONVEYOR BELT

